

Honeywell

MS4120F; MS4620F,S; MS8120F,S; S2024-F; S20230-F

FAST-ACTING, TWO-POSITION ACTUATORS

PRODUCT DATA



APPLICATION

The MS4120F, MS4620F, MS8120F, S2024-F, and S20230-F Fast-Acting, Two-Position Actuators are spring return direct coupled actuators (DCA) for on/off damper control. The actuator accepts an on/off signal from a single-pole, single-throw (spst) controller. Reversible mounting allows actuator to be used for either clockwise (cw) or counterclockwise (ccw) spring rotation.

Designed to operate reliably in smoke control systems requiring Underwriter's Laboratories Inc. UL555S ratings up to 350°F, if applicable.

APPLICABLE LITERATURE

- | | |
|-------------------------------------------------------------------------|---------|
| – Specification Data Sheet | 63-2592 |
| – Engineering Manual of Automatic Control (also called The Gray Manual) | 77-1100 |

FEATURES

- 175 lb-in. (20 Nm) minimum driving torque at 350°F (176°C).
- Reversible mounting facilitates use in either clockwise (cw) or counterclockwise (ccw) spring rotation.
- Integral spring return ensures level of return torque.
- Stainless steel internal spring.
- Fifteen-second spring return timing.
- No special cycling required during long-term holding. (See Operation section.)
- No audible noise during holding.
- Models available for 24, 120, and 230 Vac applications.
- Ninety-five degree angle of rotation.
- Actuator holds rated torque at reduced power level.
- Die-cast aluminum housing.
- Housing design allows flush mounting to damper.
- Patented Self-Centering Shaft Adapter (SCSA). Patent Number: US 6,505,991
- Designed to operate reliably in smoke control systems requiring Underwriter's Laboratories Inc. UL555S ratings up to 350°F.
- Non-UL marked models available.
- 5 year warranty from date of installation.

MS4120F, MS4620F, MS8120F

- High temperature Teflon[®] lead wires.
- Models available with integral high temperature (350°F) SPST position-indicating switches (7°, 85° stroke).

S2024-F, S20230-F, MS4620S, MS8120S

- Double-insulation rating.
- High-temperature, halogen-free, silicone-free leadwires.
- Models available with integral high temperature (350°F) SPDT position-indicating switches (7°, 85° stroke).



63-2584-14

SPECIFICATIONS

Models: See Tables 1, 3, and 4.

Table 1. Models.

Model	Voltage in Vac	Internal Auxiliary Switches
MS4120F1006	120	None
MS4120F1204	120	2 SPST ^a
MS4620F1005	230	None
MS4620F1203	230	2 SPST ^a
MS8120F1002	24	None
MS8120F1200	24	2 SPST ^a
S2024-F (MS8120S1006)	24	None
S20230-F (MS4620S1009)	230	
S2024-F-SW2 (MS8120S1204)	24	2 SPDT ^a
S20230-F-SW2 (MS4620S1207)	230	

^a Internal switches are designed to pass UL555S requirements (at 350°F) if applicable.

Dimensions: See Fig. 1.

Device Weight:

MS4120F, MS4620F, S20230-F: 7.5 lb (3.4 kg)
MS8120F, S2024-F: 6.25 lb (2.8 kg)

Stroke: 95° ± 3°, mechanically limited.

Electrical Ratings:

Table 2.

Model	Power Input	Driving Power	Holding Power
MS4120F	120 Vac ±10%, 60 Hz	0.35A, 35W	0.15A, 10W
MS4620F,S ; S20230-F	230 Vac ±10%, 50/60 Hz	0.20A, 35W	0.14A, 10W
MS8120F,S ; S2024-F	24 Vac +20%, -10%, 50/60 Hz (Class 2)	45VA	10VA

Electrical Connections:

Lead Wires:

MS4120F, MS4620F, MS8120F: 1m Teflon wire.

MS4620S, MS8120S, S2024-F, S20230-F: 1m halogen-free, silicone-free wire.

Two integral 3/8 in. flexible conduit connections.

Timing (At Rated Torque and Voltage):

Drive Open: 15 seconds typical.

Spring Close: 15 seconds typical.

Auxiliary Switches:

Dry Contact

Ratings (maximum load): 250 Vac, 5A resistive.

Settings (fixed): 7° nominal stroke, 85° nominal stroke.

Torque Rating (at Rated Voltage):

Typical Holding (minimum at 350°F): 175 lb-in. (20 Nm).

Spring Return (minimum at 350°F): 175 lb-in. (20 Nm).
Stall Maximum (fully open at 75°F): 425 lb-in. (48.0 Nm).
350°F Minimum Driving: 175 lb-in. (20 Nm).

Design Life (at Rated Voltage): 30,000 full stroke cycles.

Minimum Damper Shaft Length:

1 in. (25 mm); 3-1/4 (83 mm) recommended.

Cycling Requirements:

Prolonged holding-period (1 year) testing of these actuators has been performed with no spring return failures.

The actuator and the internal spring are designed to require no special cycling during long-term holding.

Honeywell recommends following all local, state and national codes for periodic testing of the entire smoke control system. Refer to National Fire Protection Association (NFPA) National Fire Codes®: NFPA90A, NFPA92A and NFPA92B for your application.

NFPA recommends periodic examination of each fire/smoke damper (semi-annually or annually) to ensure proper performance.

Mounting: Self-centering shaft adapter.

Round Damper Shafts: 0.5 to 1.06 in.

Square Damper Shafts: 1/2 to 3/4 in.

Actuator can be mounted with shaft in any position.

IMPORTANT

- Honeywell does not recommend using linkages with these actuators because side-loading of the output hub reduces actuator life.
- 3/4 in. or greater shaft diameter recommended.

Noise Rating at 1m (Typical):

Driving or Spring Return: 70 dBA.

Holding: 20 dBA (no audible noise).

Vibration:

Not suitable for high vibration applications (Example installation environment: Truck Trailers or Railroad Cars)
Acceptable Vibration Levels 0.6g at 30 to 300 Hz.

Temperature Ratings:

Ambient: -40°F to 130°F (-40°C to 55°C).

Shipping and Storage: -40°F to 140°F (-40°C to 60°C).

IMPORTANT

The actuator is designed to meet UL555S standards at 350°F (176°C) on applicable marked models. The actuator must be tested with the damper to achieve this rating.

NOTE: The actuator is designed to operate for 30 minutes during a one-time excursion to 350°F (176°C).

Humidity Ratings: 5% to 95% RH noncondensing.

Environmental Protection Ratings:

NEMA2 and IP54 when mounted on a horizontal shaft and the base of the actuator below the shaft.

Accessories:

205649 Mounting Bracket (not supplied with actuator).

Approvals: See Table 5.

Controller Type:

MS4120F: Line voltage (120 Vac), 2-position, spst (Series 40).

MS4620F,S; S20230-F: Line voltage (230 Vac), 2-position, spst (Series 40).

MS8120F,S; S2024-F: Low voltage (24 Vac), 2-position, spst (Series 80).

Table 3. Actuator Selection (MS Series).

M	Electrical Motor
S	Fail Safe Function (Spring Return)
41	120 Vac 2-position Control; Reversible Mount Spring Return
46	230 Vac 2-position Control; Reversible Mount Spring Return
81	24 Vac 2-position Control; Reversible Mount Spring Return
20	175 lb-in. (20 N•m)
F	Fire and Smoke (US)
S	Fire and Smoke (EU)
1	No Feedback
0	No Auxiliary Switches
2	Two Auxiliary Switches
XX	System Controlled Numbers
-	UL Marked
NM	No Marking

M	S	41	20	F	1	2	XX	
---	---	----	----	---	---	---	----	--

Table 4. Actuator Selection (S20 Series).

S	Fail Safe Function (Spring Return)
20	20 N•m (175 lb-in.)
24	24 Vac 2-position Control; Reversible Mount Spring Return
23	230 Vac 2-position Control; Reversible Mount Spring Return
0	
F	Fire and Smoke Actuator
	No Auxiliary Switches
-SW2	Two Auxiliary Switches

S	20	24	-	F	-SW2
---	----	----	---	---	------

Table 5. Approvals.

	MS4120F	MS4620F, MS8120F	S20230-F, MS4620S	S2024-F, MS8120S
UL/cUL (optional)	X	X		
UL60730/CSA E60730 -1,-2-14 Plenum Rating, File No. E4436; Guide No. XAPX. ^a (optional)	X	X		
CE	X	X	X	X
C-TICK		X	X	X

^a Plenum applications require that conductors be enclosed in conduit (see Wiring section for conduit details).

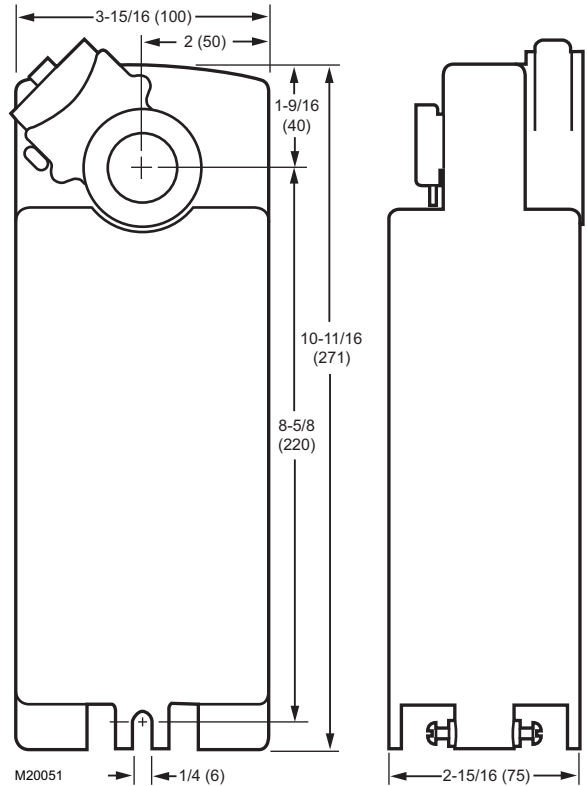

Fig. 1. Dimensional drawing of actuator in in. (mm).

INSTALLATION

When Installing this Product...

1. Read these instructions carefully. Failure to follow them could damage the product or cause a hazardous condition.
2. Check the ratings given in the instructions and on the product to make sure the product is suitable for your application.
3. Installer must be a trained, experienced service technician.
4. After installation is complete, check out product operation as provided in these instructions.



WARNING

Electrical Power Hazard.
Line voltage can cause death or serious injury and short equipment circuitry.
Disconnect power supply before installation.





CAUTION

Electrical Shock or Equipment Damage Hazard.
Low voltage can shock individuals or short equipment circuitry.
Disconnect power supply before installation.

IMPORTANT

All wiring must agree with applicable codes, ordinances and regulations.

Location

The actuators are designed to open a damper by driving the damper shaft in either a clockwise  or counterclockwise  direction. The actuator housing has two slots on the bottom, either of which, with a 205649 Mounting Bracket, secures it flush to a damper box (see Fig. 2).

NOTE: When mounted correctly, these slots allow the actuator to *float* without rotating relative to the damper shaft.



CAUTION

Equipment Damage Hazard.

Tightly securing actuator to damper housing can damage actuator.

Mount actuator to allow it to float along its vertical axis.

Preparation

Before mounting the actuator onto the damper shaft, determine the:

- Damper/valve opening direction for correct spring return rotation. The actuator can be mounted to provide clockwise or counterclockwise spring return.
- Damper shaft size (see Specifications section).

Determine Appropriate Mounting Orientation

See Fig. 2 for mounting orientation.

NOTES:

- Actuators are shipped in the fully closed position.
- An arrow molded into the hub points to tick marks on the label to indicate the hub rotary position.
- See Fig. 3 for proper mounting to a square damper shaft.

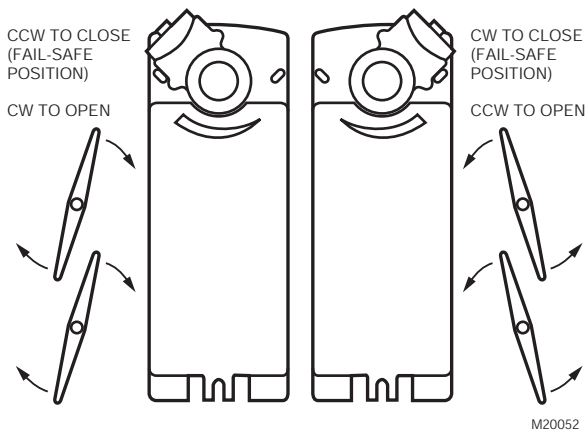

Fig. 2. Spring Return DCA mounting orientation.

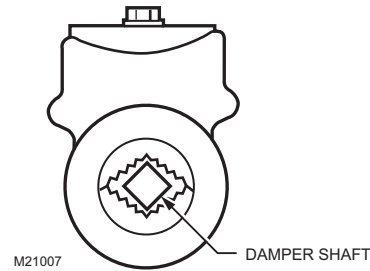

Fig. 3. Proper mounting to square damper shaft.

Measure Damper/Valve Shaft Length

If the shaft is less than three inches in length, the shaft coupling must be located between the damper/valve and actuator housing. If the shaft length is more than three inches, the shaft coupling may be located on either side of the actuator housing.

If the coupling must be moved from one side of the actuator to the reverse, follow these instructions (see Fig. 4):

1. Remove the retainer clip from the shaft coupling and set it aside for later use.
2. Remove shaft coupling from one side of the actuator.
3. Replace the shaft coupling on the opposite side of the actuator aligning it based on the stroke labelling.
4. Replace the retainer clip on the shaft coupling using the groove of the coupling.

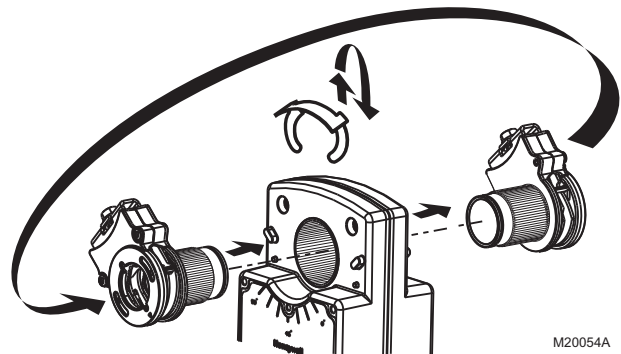

Fig. 4. Mounting shaft coupling to actuator opposite side.

Mounting



CAUTION

Device Malfunction Hazard.

Improper shaft coupling tightening causes device malfunction.

Tighten shaft coupling with proper torque to prevent damper shaft slippage.



CAUTION

Actuator Damage Hazard.

Using actuator as shaft bearing causes device damage.

Use actuator only to supply rotational torque. Avoid any side loads to actuator output coupling bearings.

To mount actuator, proceed as follows:

1. Place actuator over damper shaft; and hold mounting bracket in place. See Fig. 5.
2. Mark screw holes on damper housing.
3. Remove actuator and mounting bracket.
4. Drill or center-punch holes for mounting screws (or use no.10 self-tapping sheet metal screws).

NOTE: If necessary, use a field-fabricated steel base plate secured with sheet metal screws.

5. Turn damper blades to desired normal (closed) position.
6. Place actuator and mounting bracket back into position and secure bracket to damper box with sheet metal screws.
7. Using 10 mm wrench, tighten shaft coupling securely onto damper shaft using minimum 120 lb-in., maximum 180 lb-in. torque.

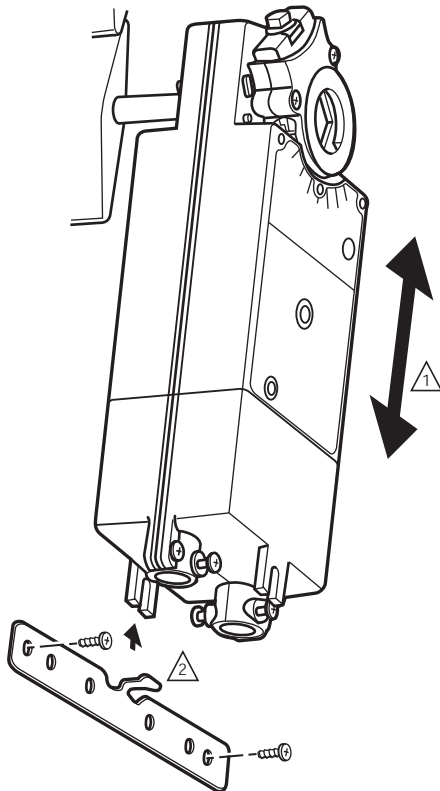

1 ENSURE THAT MOUNTING ASSEMBLY PREVENTS ACTUATOR ROTATION AND ALLOWS ACTUATOR TO FLOAT ALONG INDICATED AXIS. WHEN TOO TIGHT, THE RESULTING BINDING CAN DAMAGE THE ACTUATOR OR REDUCE TORQUE OUTPUT.

2 ACCESSORY MOUNTING BRACKET IS NOT SUPPLIED WITH THE ACTUATOR. M20055

Fig. 5. Mounting actuator to damper housing.

Manual Positioning

The actuator can be operated with no power present. Use this feature during installation or to move and lock the damper or valve shaft position when there is no power.

To operate the manual positioning:

1. If the power is on, turn it off.
2. Insert supplied hex wrench (key) as shown in Fig. 6.
3. Rotate key in the direction indicated on the cover.
4. Once the desired position is reached, hold the key to prevent the spring return from moving the actuator.

NOTE: No detente for fire and smoke actuators. If key is released, actuator will return to spring closed position.

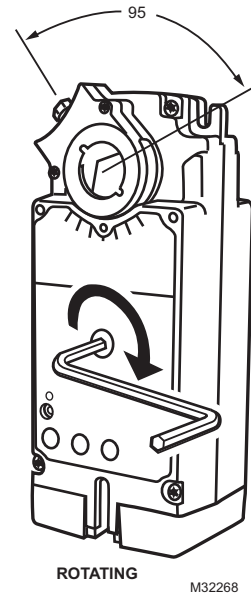

Fig. 6. Manual positioning.

WIRING

See Fig. 7 through 11 for typical wiring diagrams.

! WARNING
Electrical Power Hazard.
 Line voltage can cause death or serious injury and short equipment circuitry.
 Disconnect power supply before installation.

! CAUTION
Electrical Shock or Equipment Damage Hazard.
 Disconnect all power supplies before installation.
 Motors with auxiliary switches can have more than one disconnect.

- IMPORTANT**
1. All wiring must comply with local electrical codes, ordinances and regulations.
 2. Voltage and frequency of transformer used with MS8120F,S and S2024-F must correspond with the characteristics of power supply and actuator.

NOTE: The conduit fittings are designed for use with 3/8 in. reduced-wall steel or aluminum flexible conduit.

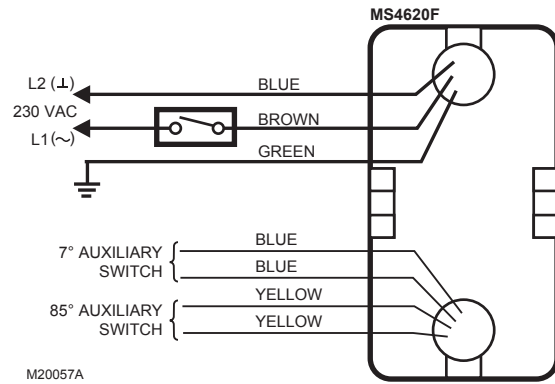

Fig. 9. Typical 230 Vac wiring (MS Series).

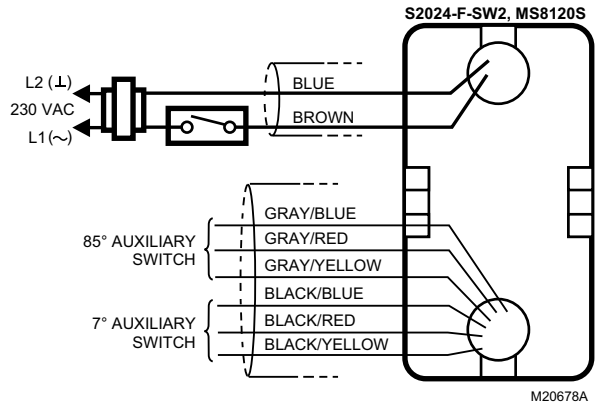

Fig. 10. Typical 24 Vac wiring (S20 Series).

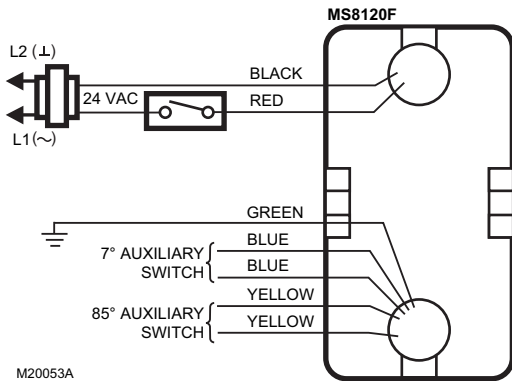

Fig. 7. Typical 24 Vac wiring (MS Series).

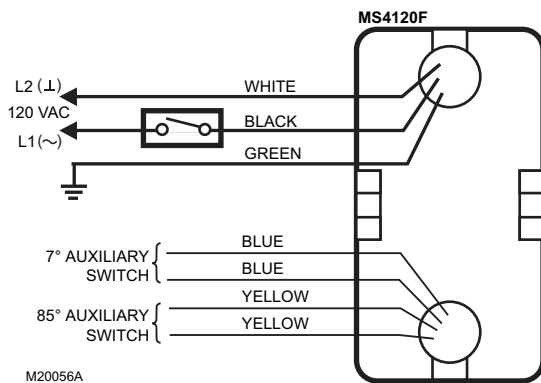

Fig. 8. Typical 120 Vac wiring (MS Series).

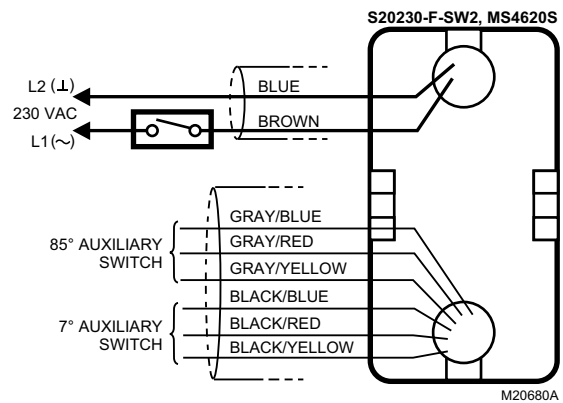

Fig. 11. Typical 230 Vac wiring (S20 Series).

OPERATION

The actuators are designed for use in Smoke Control Systems. If power fails, the actuator spring returns to the 0° position. The actuator mounts flush with the damper box. The actuator drives from 0° to 95° and spring returns back to 0°.

The actuators are operated by an spst two-position controller. When using an spst two-position controller, the actuator drives to the damper fully open position when controller contact makes and spring returns to the damper fully closed position when controller contact breaks. The actuator drops to holding power level on detection of stall, independent of hub position.

Cycling

The actuator and the internal spring are designed so that no special cycling during long-term holding is required. Honeywell recommends following all local, state, and national codes for periodic testing of the entire smoke control system. Refer to National Fire Protection Association (NFPA) National Fire Codes®: NFPA90A, NFPA92A, and NFPA92B for your application.

Auxiliary Switches

Some models include auxiliary switches (see Table 1).

SPST Switches (Table 6)

See Fig. 7 through 9 for SPST auxiliary switch wiring.

Table 6. SPST Auxiliary Switch Operation.

Switch	Wire Color	Makes	Breaks
		(degrees from fully closed position)	
7°	blue	less than 7	greater than 7
85°	yellow	greater than 85	less than 85

NOTE: Both sets of contacts are open when the actuator is between 7° and 85°.

SPDT Switches (Fig. 12)

See Fig. 10 through 12 for SPDT auxiliary switch wiring.

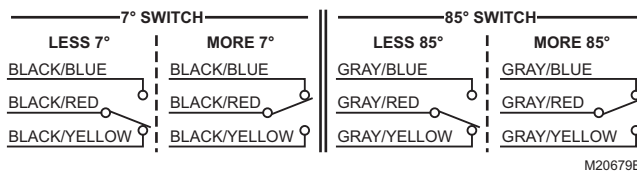

Fig. 12. SPDT auxiliary switch operation.

CHECKOUT

MS4120F (120 Vac model)

1. Check damper position.
2. Connect 120 Vac to the black and white leadwires to drive the damper to the open position. The actuator should drive the damper.
3. If the actuator does not run, remove power for at least two seconds.
4. If the actuator spring returns, allow it to close entirely, then return to step 2.
5. If the actuator does not spring return, verify that the actuator is properly installed. See Installation section.
6. If the actuator is correctly installed but neither runs nor spring returns, replace the actuator.

MS4620F,S; S20230-F (230 Vac models)

1. Check damper position.
2. Connect 230 Vac to the blue and brown leadwires to drive the damper to the open position. The actuator should drive the damper.
3. If the actuator does not run, remove power for at least two seconds.
4. If the actuator spring returns, allow it to close entirely, then return to step 2.
5. If the actuator does not spring return, verify that the actuator is properly installed. See Installation section.
6. If the actuator is correctly installed but neither runs nor spring returns, replace the actuator.

MS8120F,S; S2024-F (24 Vac models)

1. Check damper position.
2. Connect 24 Vac to the red and black leadwires to drive the damper to the open position. The actuator should drive the damper.
3. If the actuator does not run, remove power for at least two seconds.
4. If the actuator spring returns, allow it to close entirely, then return to step 2.
5. If the actuator does not spring return, verify that the actuator is properly installed. See Installation section.
6. If the actuator is correctly installed but neither runs nor spring returns, replace the actuator.

D Montageanweisung
 F Instructions d'Installation
 I Istruzioni per l'Installazione

NL Installatievoorschrift
 DK Installasjonsinstruks
 N Installationsinstruktioner

SF Asennusohje
 S Installations Instruktioner
 E Instrucciones de montaje

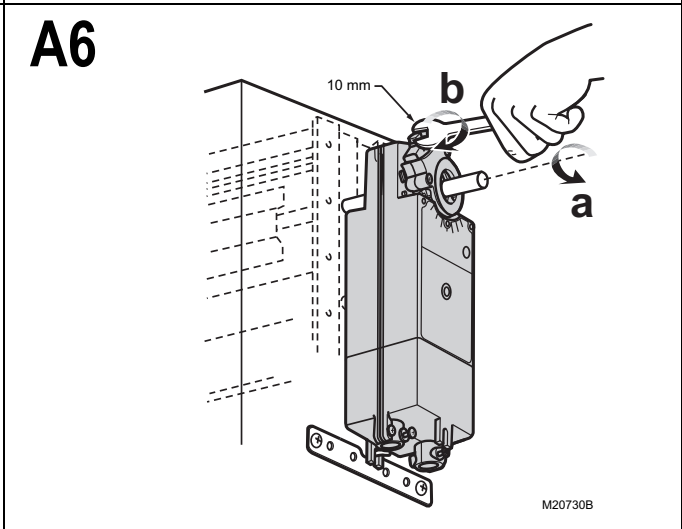
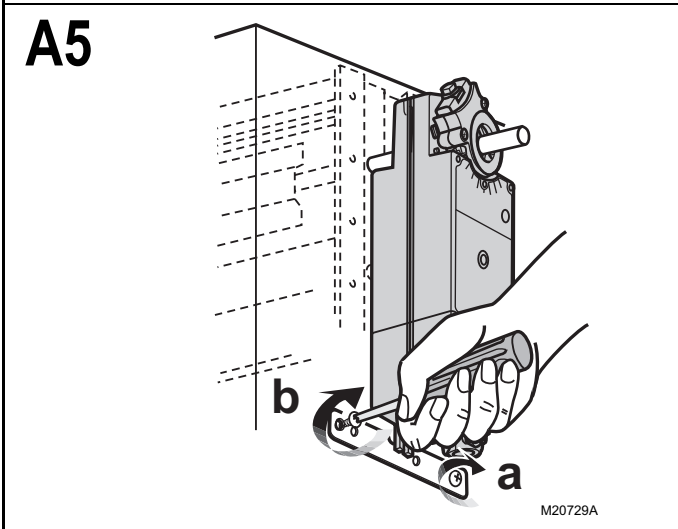
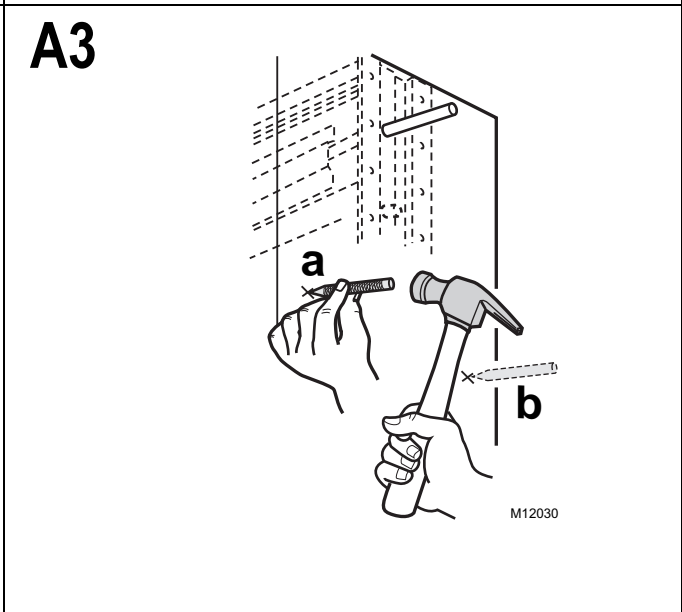
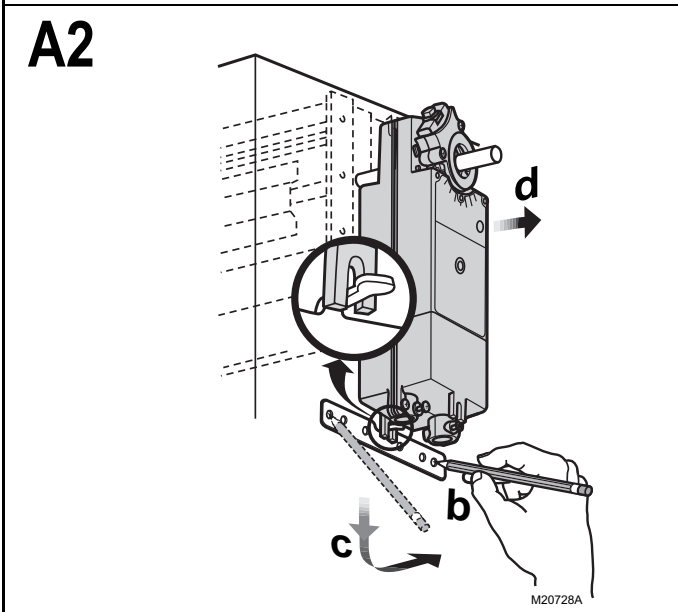
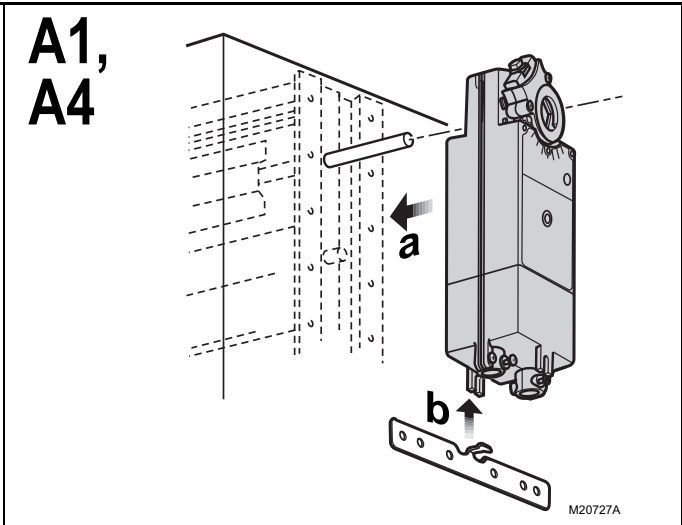
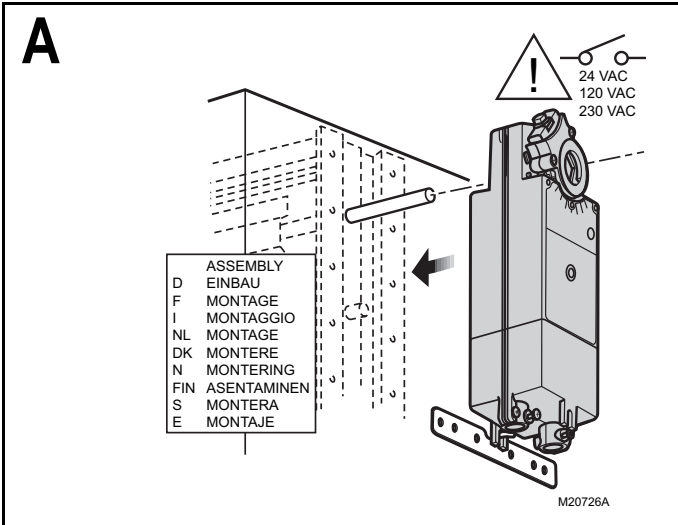

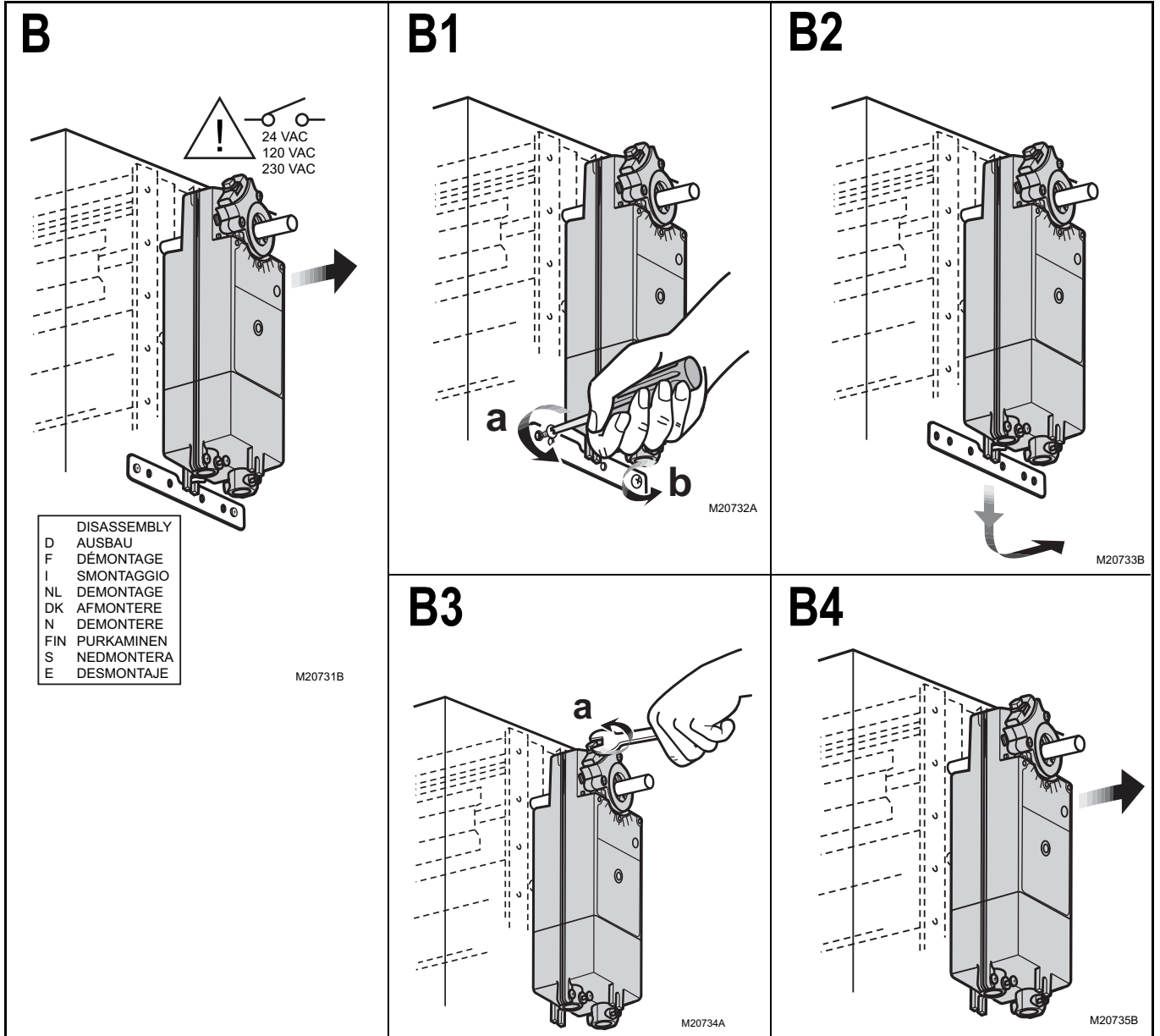

MS4120F; MS4620F,S; MS8120F,S; S2024-F; S20230-F

MS4120F; MS4620F,S; MS8120F,S; S2024-F; S20230-F

Teflon® is a registered trademark of the E.I. du Pont de Nemours and Company.

National Fire Codes® is a registered trademark of the National Fire Protection Association (NFPA).

By using this Honeywell literature, you agree that Honeywell will have no liability for any damages arising out of your use or modification to, the literature. You will defend and indemnify Honeywell, its affiliates and subsidiaries, from and against any liability, cost, or damages, including attorneys' fees, arising out of, or resulting from, any modification to the literature by you.

Home and Building Technologies

In the U.S.:

Honeywell

1985 Douglas Drive North

Golden Valley, MN 55422-3992

customer.honeywell.com

Honeywell

® U.S. Registered Trademark
© 2016 Honeywell International Inc.
63-2584-14 M.S. Rev. 11-16
Printed in United States