

**QUALIFICATIONS:**

- **UL 555 & CAN/ULC-S112 CLASSIFIED DYNAMIC FIRE DAMPER** 1 1/2 hr. Label (File # R9492).
- **UL 555S CLASSIFIED SMOKE DAMPER** (File # R9492) Leakage Class I at 250°F or 350°F elevated temperature.
- **Meets NFPA 80, 90A, 92, 101 and 105 as well as IBC and NBC (Canada) Building Code requirements.**
- **City of New York. MEA # 366-03-M.**
- **California State Fire Marshal: Fire Damper Listing No. 3225-0935:0106.**
- **Maximum velocity: 4000 fpm @ 4" w.g. (20 m/s @ 1 kPa).**

Model 770-TR Damper is ideal for applications where building codes require both a fire damper for the protection of ductwork penetrations in walls or floors that have a fire resistance rating of up to 2 hours and also require a leakage rated damper for operational smoke control in static or dynamic smoke management systems.

The 770-TR Damper is an economical true round combination fire/smoke damper designed and qualified for round ductwork passing through metal or wood stud drywall partitions and masonry walls or floors. The 770-TR offers the lowest leakage class available and is qualified for installation with airflow in either direction.

**STANDARD CONSTRUCTION:**

- Frame:** 20 ga. (1.0) galvanized steel integral sleeve and retaining plates.
- Blades:** 2 x 20 ga. (1.0) galvanized steel laminated together. 14 ga. (2.0) equivalent thickness.
- Linkage:** Jackshaft to blade.
- Bearings:** 1/2" (13) dia. self-lubricating oilite bronze.
- Axles:** 1/2" (13) dia. plated steel double bolted to blades.
- Jackshaft:** 1/2" (13) dia. cadmium plated steel.
- Blade Seal:** Silicone rubber. Peripheral gasket sandwiched between two piece blade.
- Heat Responsive Device (Controlled Closure):**  
 ERL (Electric Resettable Link) is standard on dampers with electric actuators: 250°F (121°C) standard. 165°F (74°C), 212°F (100°C) and 350°F (177°C) available.  
 PRL (Pneumatic Replaceable Link) is standard on dampers with pneumatic actuators: 212°F (100°C) standard. 165°F (74°C) and 280°F (138°C) available.

**Sizes (Duct Dia.):**

Minimum	Maximum
6" (152) dia.	24" (610) dia.

**Note:** Dampers available in 2" (51) increments.

**LEAKAGE CLASS / ELEVATED TEMPERATURE:**

- I @ 250°F (Standard)
- I @ 350°F

**DYNAMIC VELOCITY / PRESSURE RATING:**

- 2000 fpm @ 4" w.g. (10 m/s @ 1 kPa) (Standard)
- 3000 fpm @ 4" w.g. (15 m/s @ 1 kPa)
- 4000 fpm @ 4" w.g. (20 m/s @ 1 kPa)

**ACTUATOR SELECTION:**

- Electric**    **Pneumatic** Specify model \_\_\_\_\_ .
- Actuators are mounted out of airstream only.

**ACTUATOR FAIL POSITION:**

Normally Closed. (Normally Open actuators are not available).

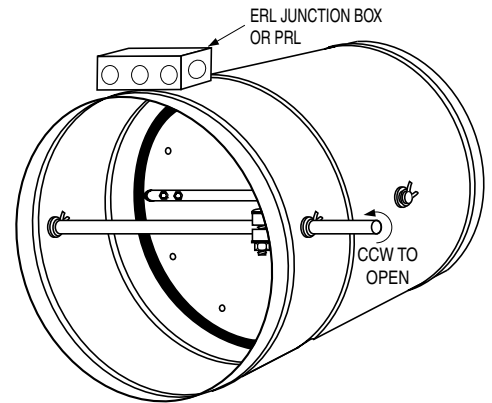

(Retaining Plates not shown)

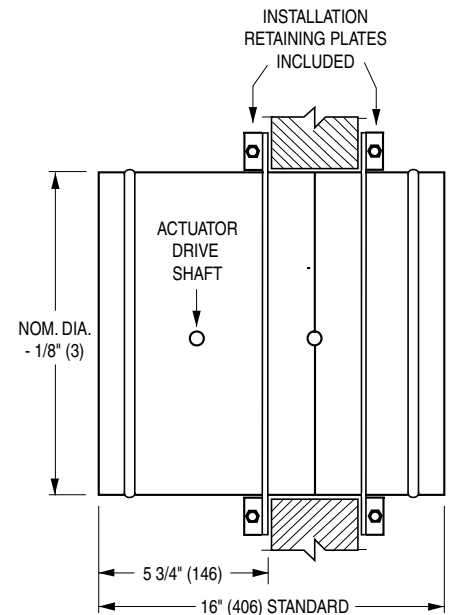

Wall Thickness	Minimum Sleeve Length
4 to 8 (102 to 203)	16 (406)
10 to 12 (254 to 305)	20 (508)
14 to 16 (356 to 406)	24 (610)

**OPTIONS:**

- 304 Stainless steel construction
- Position indicator switch pack
- Electric Fire Sensor (Re-openable control system). Includes dual heat sensors (165°F and 250°F or 350°F) and position indicator switch pack.

For installation instructions, see IOM-770TRINST.  
 Dimensions are in inches (mm).

<b>SCHEDULE TYPE:</b>	<b>DATE</b>	<b>B SERIES</b>	<b>SUPERSEDES</b>	<b>DRAWING NO.</b>
<b>PROJECT:</b>	6 - 22 - 21	770	NEW	770-TR-1
<b>ENGINEER:</b>				
<b>CONTRACTOR:</b>				