

## Industrial Control Dampers – Models ARO-3 & ARM-3

**Design Features** – Galvanized Steel Industrial Control Damper with corrugated V-blade design for low-pressure drop and high static pressure applications in industrial systems.

### STANDARD CONSTRUCTION

**FRAME**

8" x 2" x 14 gauge galvanized steel channel to 1/4" steel channel

**BLADES**

5" to 8" wide, 16 gauge galvanized steel to 1/4" thk.

**ARO** – Opposed Blade

**ARM** – Parallel Blade

**BLADE AXLES & BEARINGS**

AXLE – 1/2" to 1" dia.

BEARING – Sleeve press-fit

**LINKAGE**

Plated steel linkage concealed in channel (standard construction)

**MAXIMUM SIZE**

Unlimited, with mullions, structural bracing supplied by others

**MAXIMUM SINGLE SECTION**

48" W x 96" H (I.D)

**MINIMUM SIZE**

6" W x 6" H (I.D)

**MAXIMUM TEMPERATURE**

250 Deg. Fahrenheit

**FINISH**

Mill Finish

**OPERATOR**

None

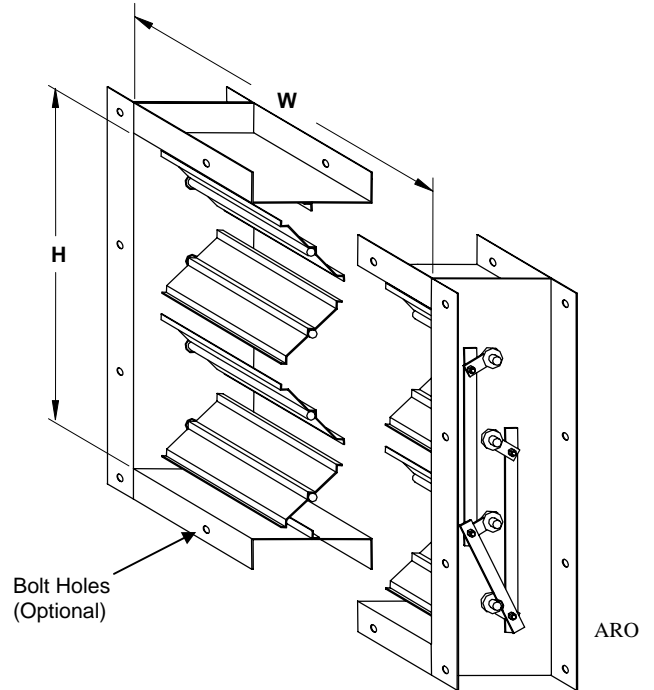

### OPTIONAL CONSTRUCTION

**SPECIFIED MATERIAL** – Available in stainless steel

**BLADE AXLES & BEARINGS** – 1-1/2" to 2" dia

**SLEEVE AND DUCTWORK CONNECTION** – 10 ga. to 16 ga. galvanized steel to 30" in length. – Transitions available in: round, oval, rectangular or custom. Factory can install access door, retaining angles, or flange connections.

**FINISH** – Air-dry primer, polyurethane, epoxy, or enamel, Baked epoxy or special finishes available

**OPERATOR** – Manual, electric or pneumatic, please consult operator listing. (Operator type and location will affect the temperature rating of the damper)

**SEALS** – Silicone Blade seals and Stainless Steel jamb seals available

**BOLT HOLES** – Bolt Holes in flange available

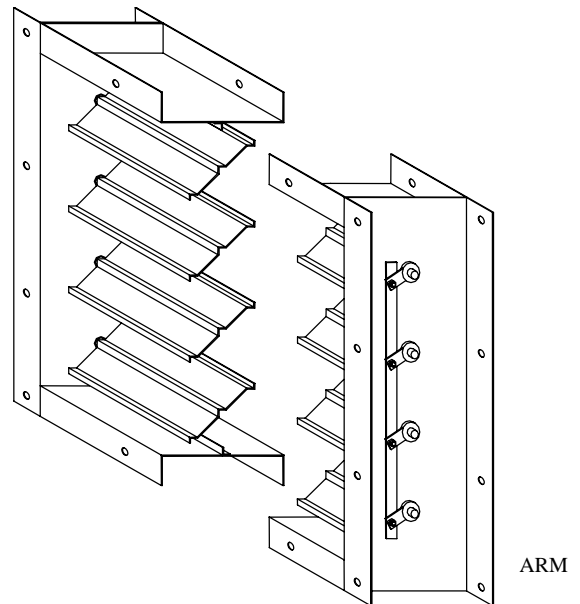

DATE	ARCHITECT			CUSTOMER
PROJECT				
ITEM	QTY	W	H	DESCRIPTION

## ARO-3 & ARM-3 PERFORMANCE

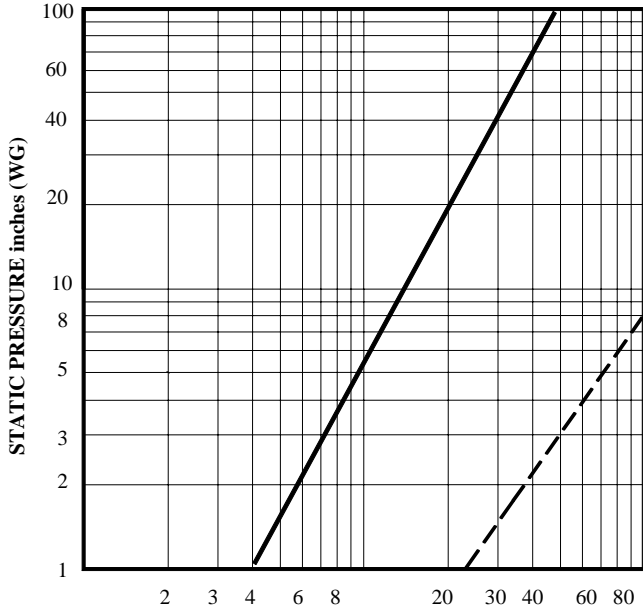

AIR LEAKAGE (CFM/ft sq.)  
48" x 48" Damper

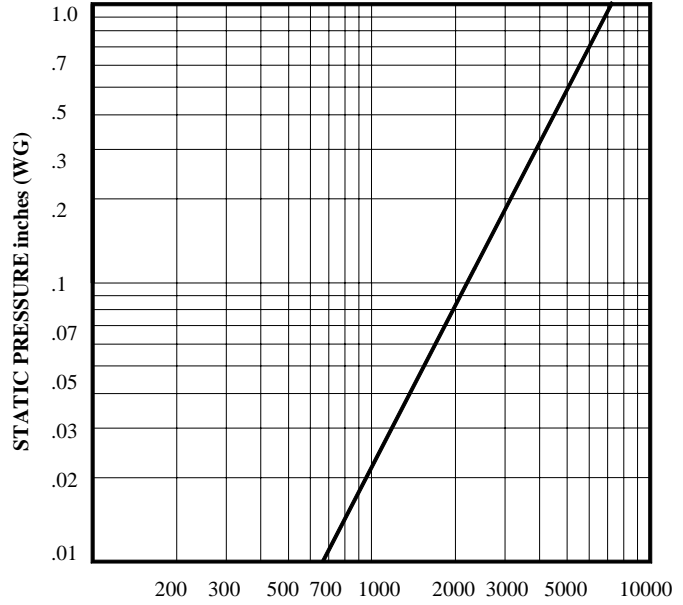

AIR VELOCITY (FPM through face area)  
24" x 24" Damper

SOLID LINE – LEAKAGE W/ SEALS —————

DASHED LINE – LEAKAGE W/OUT SEALS - - - - -

### FREE AREA CALCULATIONS IN SQ. FT.

#### WIDTH

Damper Width Inches	Maximum Static Pressure (W.G.)	Maximum Velocity
12"	20"	7000 FPM
24"	16"	7000 FPM
36"	12"	7000 FPM
48"	10"	7000 FPM

HEIGHT

Inches	12	16	20	24	28	32	36	40	44	48
12	0.88	1.17	1.46	1.75	2.05	2.34	2.63	2.92	3.21	3.50
16	1.21	1.62	2.02	2.42	2.82	3.23	3.63	4.03	4.44	4.84
20	1.48	1.98	2.47	2.96	3.46	3.95	4.44	4.94	5.43	5.92
24	1.75	2.34	2.92	3.50	4.09	4.67	5.25	5.84	6.42	7.00
28	2.03	2.70	3.37	4.05	4.72	5.39	6.07	6.74	7.41	8.09
32	2.36	3.14	3.93	4.71	5.50	6.28	7.07	7.85	8.64	9.42
36	2.63	3.50	4.38	5.25	6.13	7.00	7.88	8.75	9.63	10.50
40	2.90	3.87	4.83	5.80	6.76	7.73	8.69	9.66	10.62	11.59
44	3.17	4.23	5.28	6.34	7.39	8.45	9.50	10.56	11.62	12.67
48	3.50	4.67	5.84	7.00	8.17	9.34	10.50	11.67	12.84	14.00
52	3.78	5.03	6.29	7.55	8.80	10.06	11.32	12.57	13.83	15.09
56	4.05	5.39	6.74	8.09	9.44	10.78	12.13	13.48	14.82	16.17
60	4.32	5.75	7.19	8.63	10.07	11.50	12.94	14.38	15.82	17.25
64	4.65	6.20	7.75	9.30	10.85	12.39	13.94	15.49	17.04	18.59
68	4.92	6.56	8.20	9.84	11.48	13.12	14.75	16.39	18.03	19.67
72	5.19	6.92	8.65	10.38	12.11	13.84	15.57	17.30	19.03	20.75
76	5.53	7.37	9.21	11.05	12.89	14.73	16.57	18.41	20.25	22.09
80	5.80	7.73	9.66	11.59	13.52	15.45	17.38	19.31	21.24	23.17
84	6.07	8.09	10.11	12.13	14.15	16.17	18.19	20.21	22.23	24.25
88	6.40	8.53	10.66	12.80	14.93	17.06	19.19	21.32	23.46	25.59
92	6.67	8.89	11.12	13.34	15.56	17.78	20.00	22.23	24.45	26.67
96	6.94	9.25	11.57	13.88	16.19	18.50	20.82	23.13	25.44	27.75