

**EXTRUDED ALUMINUM COMBINATION LOUVER/DAMPER**  
**4" (102) DEEP • DRAINABLE BLADE**  
**OPERABLE DAMPER**  
**MODEL: C-DWE-44**

Safe-Air Model C-DWE-44 is an extruded aluminum combination louver and damper that incorporates front stationary drainable blades and rear adjustable blades all within a single frame. The design provides efficient air performance and aesthetics that compliment any building exterior, while providing tight shut-off when no airflow is required. The drainable blades provide excellent weather protection for exhaust and low to medium velocity intake air applications by utilizing rain gutters to divert collected water down concealed side downspouts and out the sill. Blades are reinforced with full length integral bosses for strength. Model C-DWE-44 is available with channel or flanged type frame to suit most installation requirements and is licensed by AMCA for assured performance.

**STANDARD CONSTRUCTION:**

- FRAME:** 4" (102) deep, Type 6063-T6 extruded aluminum, .060" (1.3) nominal wall thickness. Integral downspouts and caulking slot provided.
- BLADES:** Front stationary blades: Drainable, Type 6063-T6 extruded aluminum, .060" (1.5) nominal wall thickness. Rear adjustable blades: Type 6063-T6 extruded aluminum, 0.80" (2.03) nominal wall thickness.
- BLADE ANGLE:** Front blades fixed at 45 degrees.
- BLADE SPACING:** Approx. 4 1/2" (114) on centers.
- BLADE SEALS:** Santoprene. Mechanically locked in place.
- JAMB SEALS:** Cambered stainless steel.
- BEARINGS:** 1/2" (13) dia. Celcon®.
- AXLES:** 1/2" (13) dia. plated steel double bolted to blades.
- LINKAGE:** Concealed in frame.
- SCREEN:** 3/4" x .050 (19 x 1.3) expanded, flattened aluminum bird screen in removable frame, inside (rear) mount (adds approximately 3/8" [10] to louver depth).
- ACTUATOR:** Hand locking louver quadrant.
- FINISH:** Mill.
- MINIMUM SIZE:** 12" W x 12" H (305 x 305).
- MAX. SINGLE SECTION SIZE:** 48" W x 96" H (1219 x 2438). Larger sizes will be manufactured in sections with visible mullion side frame (downspouts are concealed) for field assembly.

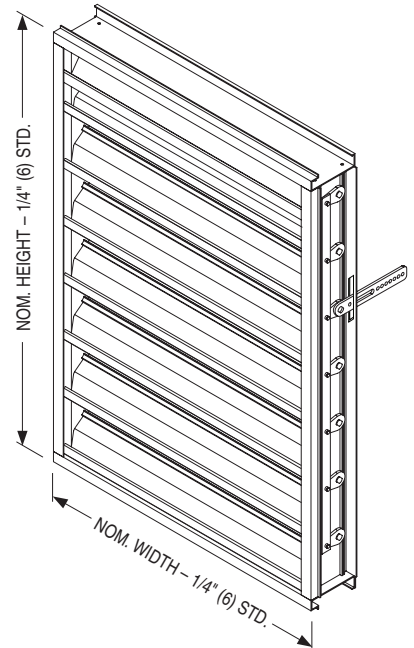

**OPTIONS:**

- FL** Flanged Frame.
- BSSS** Type 304 S.S. Bird Screen.
- BSN** No Bird Screen.
- ISA** Aluminum Insect Screen.
- ISSS** Type 304 S.S. Insect Screen.
- WE** Welded Construction.
- ESI** Extended Sill.
- FR1** 1" (25) Filter Rack.
- FR2** 2" (51) Filter Rack.
- PACA** Perimeter Anchor Clips.
- PASI** Sill Pan.
- ACT** Electric or Pneumatic Actuator. Specify: \_\_\_\_\_.
- Other:** \_\_\_\_\_.

**OPTIONAL FINISHES:**

- PC3** Powder Coat AAMA 2603. Color: \_\_\_\_\_.
- PC4** High Performance Powder Coat AAMA 2604 (Equivalent to 50% Kynar®). Color: \_\_\_\_\_.
- PC5** Fluoropolymer Powder Coat AAMA 2605 (Equivalent to 70% Kynar®). Color: \_\_\_\_\_.
- PCC** Prime Coat.
- AN04** Clear Anodized 204-R1.
- AN15** Clear Anodized 215-R1.

**Color Anodized:**

- ANLB** Light Bronze.
- ANDB** Dark Bronze.
- ANMB** Medium Bronze.
- ANBK** Black.

**OPTIONAL W x H SIZING** (1/4" [6.5] Undersize standard):

- U00** Exact Size.
- U50** Undersize 1/2" (12.7).
- U38** Undersize 3/8" (9.5).

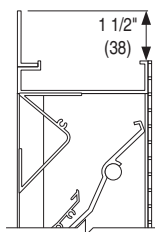

FLANGED FRAME (FL)  
(OPTIONAL)

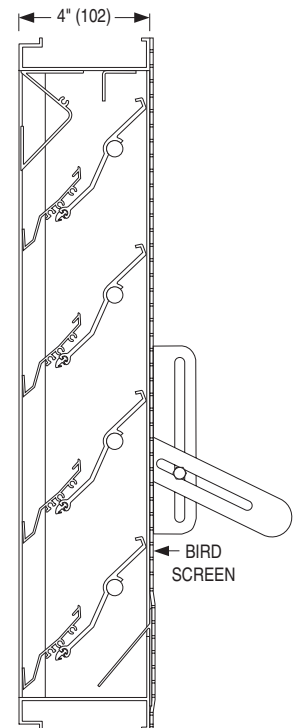

**SCHEDULE TYPE:**

**PROJECT:**

**ENGINEER:**

**CONTRACTOR:**

Page 1 of 2  
Dimensions are in inches (mm).

DATE	B SERIES	SUPERSEDES	DRAWING NO.
3 - 3 - 23	LOUVER	NEW	C-DWE-44

**FREE AREA in Square Feet and Square Meters**

		Width in Inches and Meters						
		12	18	24	30	36	42	48
Height in Inches and Meters	12	0.17	0.28	0.39	0.49	0.60	0.70	0.81
	0.30	0.02	0.03	0.04	0.05	0.06	0.07	0.08
	18	0.41	0.66	0.91	1.16	1.41	1.66	1.90
	0.46	0.04	0.06	0.08	0.11	0.13	0.15	0.18
	24	0.58	0.94	1.30	1.65	2.01	2.37	2.72
	0.61	0.05	0.09	0.12	0.15	0.19	0.22	0.25
	30	0.71	1.15	1.59	2.02	2.46	2.89	3.33
	0.76	0.07	0.11	0.15	0.19	0.23	0.27	0.31
	36	0.94	1.52	2.09	2.67	3.24	3.81	4.39
	0.91	0.09	0.14	0.19	0.25	0.30	0.35	0.41
	42	1.13	1.81	2.50	3.19	3.88	4.56	5.25
	1.07	0.10	0.17	0.23	0.30	0.36	0.42	0.49
	48	1.26	2.03	2.80	3.56	4.33	5.10	5.93
	1.22	0.12	0.19	0.26	0.33	0.40	0.47	0.55
	54	1.48	2.39	3.30	4.20	5.11	6.01	6.92
	1.37	0.14	0.22	0.31	0.39	0.47	0.56	0.64
	60	1.67	2.69	3.71	4.73	5.74	6.76	7.78
	1.52	0.16	0.25	0.34	0.44	0.53	0.63	0.72
	66	1.80	2.90	4.00	5.10	6.20	7.30	8.40
1.68	0.17	0.27	0.37	0.47	0.58	0.68	0.78	
72	2.03	3.26	4.50	5.74	6.97	8.21	9.45	
1.83	0.19	0.30	0.42	0.53	0.65	0.76	0.88	
78	2.21	3.56	4.91	6.26	7.61	8.96	10.31	
1.98	0.21	0.33	0.46	0.58	0.71	0.83	0.96	
84	2.35	3.78	5.21	6.64	8.07	9.50	10.93	
2.13	0.22	0.35	0.48	0.62	0.75	0.88	1.02	
90	2.57	4.14	5.71	7.27	8.84	10.41	11.97	
2.29	0.24	0.38	0.53	0.68	0.82	0.97	1.11	
96	2.76	4.44	6.12	7.80	9.48	11.16	12.84	
2.44	0.26	0.41	0.57	0.72	0.88	1.04	1.19	

**AIR LEAKAGE (damper fully closed)**

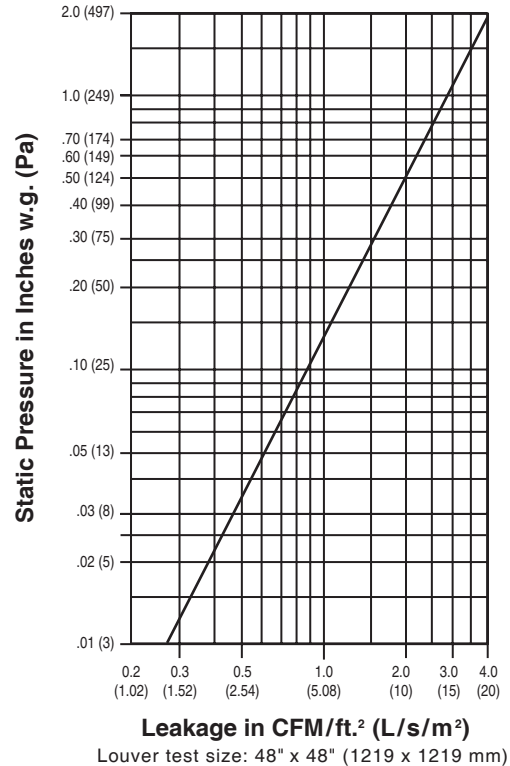

**AIRFLOW/WATER PENETRATION DATA**  
for 48" x 48" (1219 x 1219) Louver Size

Free Area %	37%	
Free Area sq. ft. (sq. m.)	5.93 (0.55)	
I N T A K E	Free Area Velocity at Point of Beginning Water Penetration at .01 oz./sq. ft. (3 ml/sq. m) (15 min. test duration)	1250 fpm (381 m/min.)*
	Air Volume at 1250 fpm Free Area Velocity	7413 cfm (3499 l/s)
	Pressure Drop @ 1250 fpm	.24 in. w.g. (60 Pa)

**NOTE:** To minimize water penetration when sizing intake louvers, select a Free Area Velocity that is **below** the point of beginning water penetration. \*Maximum Free Area Velocity tested is 1250 fpm. Beginning point of water penetration for this model is above 1250 fpm.



Safe-Air certifies the Model C-DWE-44 shown herein is licensed to bear the AMCA Seal. The ratings shown are based on tests and procedures performed in accordance with AMCA Publication 511 and comply with the requirements of the AMCA Certified Ratings Program. Seal applies to air performance ratings and water penetration ratings.

**PRESSURE DROP (damper fully open)**

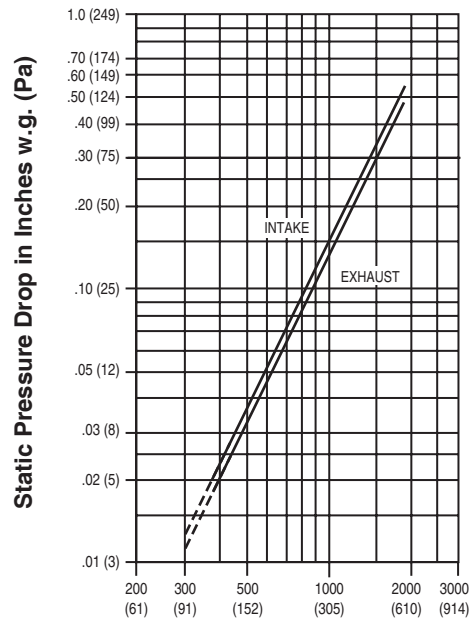

Standard air density @ 0.075 lbs/ft³. Tested to AMCA Fig. 5.5 – 6.5.

**SCHEDULE TYPE:**

**PROJECT:**

**ENGINEER:**

**CONTRACTOR:**

Page 2 of 2

Dimensions are in inches (mm).

DATE	B SERIES	SUPERSEDES	DRAWING NO.
3 - 3 - 23	LOUVER	NEW	C-DWE-44