

Heavy Duty Backdraft Damper – Model SH2B

Design Features – Airfoil blade heavy-duty back-draft damper designed for use with bi-directional airflow

STANDARD CONSTRUCTION

FRAME

12" deep x 2" channel, 10 ga. Galvanized steel

BLADES

12 gauge galvanized steel, insulated

BLADE AXLES & BEARINGS

AXLE – 1" diameter plated steel shaft

BEARINGS – 1" diameter 2-bolt flange bearing

LINKAGE

1" x 1/4" plated steel, bi-directional configuration

COUNTER WEIGHT

Adjustable, on .063" aluminum bracket

MAXIMUM VELOCITY & STATIC PRESSURE

48" wide 4000 FPM @ 9" static pressure

36" wide 4000 FPM @ 10" static pressure

24" wide 4000 FPM @ 12" static pressure

12" wide 4000 FPM @ 15" static pressure

MAXIMUM TEMPERATURE

-40° to 250° F

MAXIMUM SINGLE SECTION

60"W x 96"H

MINIMUM SIZE

6"W x 8"H

UNDERSIZED

Dampers are sized on ACTUAL INSIDE DIMENSIONS

FINISH

Mill

OPERATOR

None

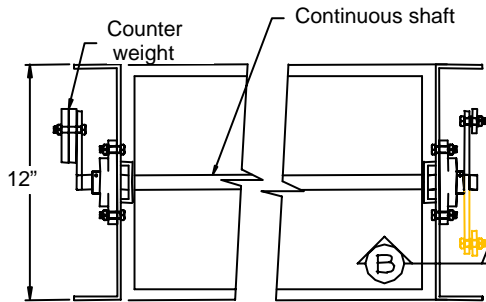
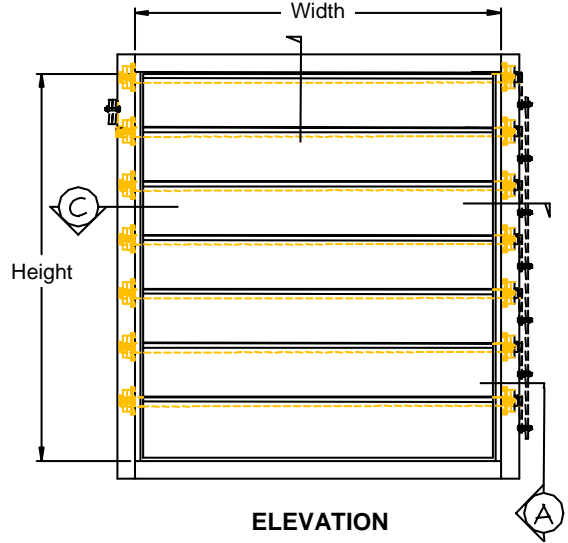

Section - C

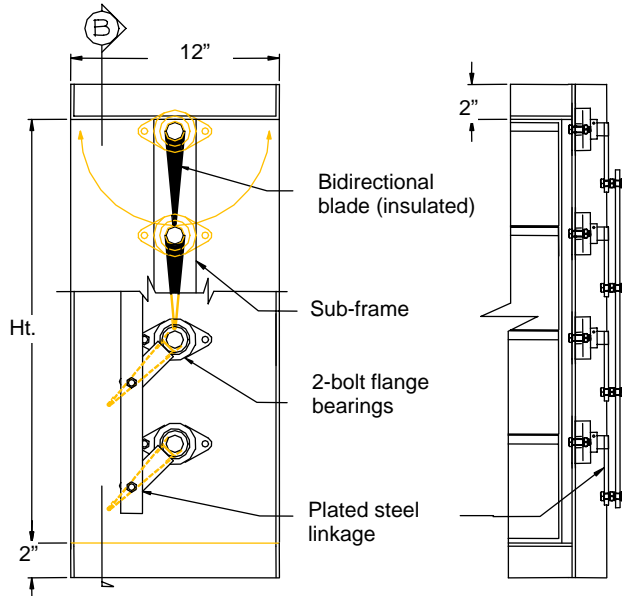

Section - A

Section - B

DATE	ARCHITECT/ENGINEER			CUSTOMER
PROJECT				
ITEM	QTY	W	H	DESCRIPTION